

NATR 20

Dimensions

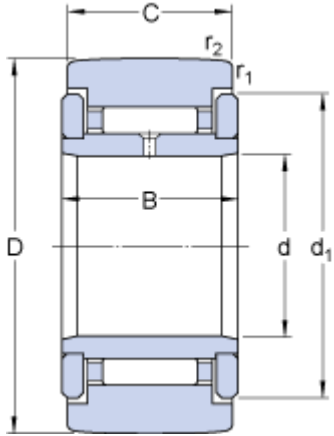

D		47	mm
d		20	mm
C		24	mm
B		25	mm
d ₁		36.5	mm
r _{1,2}	min.	1	mm

Calculation data

Basic dynamic load rating	C	14.7	kN
Basic load rating, static	C ₀	24.5	kN
Fatigue load limit	P _u	2.9	kN
Maximum static radial loads	F _r	23.6	kN
Maximum static radial loads	F _{0r}	33.5	kN
Limiting speed		3000	r/min

Mass

Mass support roller		0.246	kg
---------------------	--	-------	----